



Hirschmann

Fully Automatic Car Aerial Auta 6000 H Servicing and Repairs Booklet

Contents

- | | |
|-----------------------------------------------------------------------------|-------------|
| 1 General working principle, models, defects, ratings and test measurements | Page 2 |
| 2 Replacing the telescopic section | Page 4 |
| 3 Dismantling the operational drive | Page 5 |
| 4 Mechanical drive, dismantling and assembly | Page 6 |
| 5 Changing pressure bearing | Page 6 |
| 6 Replacing limit switch with relay plate | Page 7 |
| Spare parts list | Pages 8/9 |
| 7 Dismantling aerial drum and reassemble | Page 10 |
| 8 Changing protective sleeve (with socket) | Page 11 |
| Illustrations of text | Pages 12-16 |

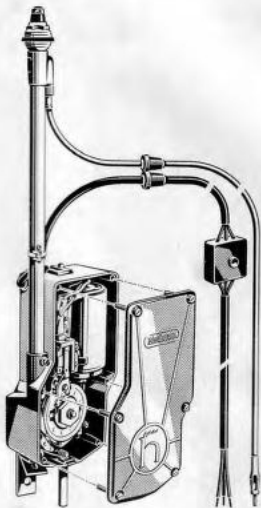

Claims under Guarantee

Our responsibilities are as stated on the Guarantee Card enclosed with every Hirschmann fully automatic car aerial. This guarantee is void if we establish that the lead seal has not been refixed after the repairs have been carried out.

Richard Hirschmann Radiotechnisches Werk

7300 Esslingen am Neckar · Ottilienstraße 19 · Postfach 110 · Telefon 390 11

Fernschreiber 07-23697

1.0 Fully automatic car aerial Auta 6000 H

The fully automatic aerial Auta 6000 H is the successor of the Auta 6000 F. The Auta 6000 H differs from the Auta 6000 F in

- its new drive principle,
- its high-performance, permanent shunt-wound electric motor,
- its new limit switch,
- taking only half the time to extend,
- practically silent movement,
- relays being mounted on a printed circuit board.

We have kept to the shell construction for the casing and top. This guarantees your being able to service the aerial as easily as before. The screwings of the top have been transferred to the inside of the casing.

1.1 Working principle

The aerial's telescopic section is extended or retracted by means of a plastic wire, which is driven by a driving plate. A pressure bearing with a spring clip presses the plastic wire into the wedge-shaped driving plate. This is moved by an adjustable slipping clutch. When the aerial is retracted, the plastic wire is wound up in a drum which runs independently. A limit switch switches off the motor and thus the drive when the telescopic section has reached its limit position while extending or retracting.

1.2 Models

The fully automatic aerial Auta 6000 H is available in two universal and several special versions for certain car models.

1.2.1 Universal models

The aerial is supplied with 12 Volt operating voltage and a telescope length of 1050 mm. Installation depths of 472 or 385 mm can be achieved by using a three-section brass telescope or a four-section stainless steel telescope.
Operating voltage for motor: 12 Volt.
Base fitment for up to 20° car body curvature.
Installation depth is thus 1050 mm (brass) 1050 mm (stainless steel)
Telescope lengths: 472 mm 385 mm

1.2.2 Special models

Operating voltage for motor: 12 Volt
Aerial head – partially permanently fixed piece.
Motor wire – varies in length, some with plug connection.
Aerial cable – varies in length and plug.
Telescope length – uniformly 1050 mm. By using brass or stainless steel, various installation lengths.
Retaining and fixing pieces – to suit car model in each case.

1.3 Model designations

1.3.1 Universal models

Auta 6000 H 15	Brass telescope	3-section	1050 mm long
Auta 6000 HS 15	Stainless steel telescope	4-section	1050 mm long

1.3.2 Special versions

Type	Ordering code	Designed for car model:
Auta 6000 H 48	924 706-001	Mercedes 190/190 D (Diesel) 1962-1964 200/200 D/230 230 S up to 1967 220/220 S 220 SE/300 SE 1958-1964
Auta 6000 H 78 ●	924 642-001	as for Auta 6000 H 48 for right-hand drive cars
Auta 6000 H 88	924 602-001	Mercedes 600
Auta 6000 H 106	924 600-001	Mercedes 250 S/250 SE/280 S/280 SE/300 SE/300 SEL/300 SEL 6,3
Auta 6000 H 118 ●	924 636-001	as Auta 6000 H 106 for right-hand drive cars
Auta 6000 H 126	924 682-001	Mercedes 200 D/220 D/200/220 230 250 260 C/CE 1968 models and later
Auta 6000 H 251 S	924 958-001	Audi 100
Auta 6000 H 351	924 718-000	BMW 2500/2600 Limousine
Auta 6000 H 352	924 710-000	BMW 2800 Coupé
Auta 6000 H 353	924 716-000	BMW 1800/2000 TI/2000 Flux August 1966 and later models
Auta 6000 H 451 S	924 574-001	Mercedes 350 SL/C
Auta 6000 H 498 S	924 910-001	Mercedes rear mounting
Auta 6000 H 651	924 720-001	NSU Ro 80

Type	Ordering code	Designed for car model:
Auta 6000 H 652 S	924 722-001	VW (Volkswagen) K 70
Auta 6000 H 852 S	924 992-001	Porsche 912/911 T/911 E/911 S 1968 and later models
Auta 6000 H 951 S	924 928-001	VW (Volkswagen) 411, VW 1500/1600

The series is being continually extended as new cars come on to the market.

- These special versions are supplied exclusively to the Motor Industry.
- S Stainless steel telescope.

1.4 Instructions for servicing and repairs

When the aerial is used, the telescopic section is exposed to the polluted air and, especially in winter, also to the spreadings which are scattered on the roads.

The telescopic section is the part of the aerial which is subject to most wear and which will thus be more liable to damage than other parts, for example when entering and leaving the garage.

There is also the possibility of wilful damage.

The whole aerial does not have to be taken out of the vehicle in order to replace a defective telescopic section (Point 2.0, page 4).

Other parts of the aerial – operational drive, limit switch, relays, pressure bearing, driving parts, drum, etc. – can only be replaced after having dismantled the aerial.

Defect	Cause	Remedy
1.4.1 Motor runs, telescope does not extend or retract fully	Telescope is very dirty	Clean telescope; if this does not help – replace telescope (Point 2.0, page 4). Do not force telescope by hand.
	Telescope sleeve or rod is bent	Replace telescope (Point 2.0, page 4)
	Aerial drum is very dirty	Dismantle aerial drum and clean (Point 7.0, page 10)
1.4.2 Motor not running, relay in working order	Fuse has blown	Replace fuse, check motor circuit for short circuit
	Motor circuit breaks	Check current circuit, deal with short circuit if necessary. Check terminals and socket connections. Check battery connections and clean
	Defective motor	Replace complete motor flange (with motor) (Point 3.0, page 5)
1.4.3 Motor not running, relay not operating	Receiver fuse has blown	Renew fuse; if it blows again, check receiver. Check pilot wire of aerial for short circuit
	Pilot wire broken	Check flat socket connections. Tighten terminals, check whether pilot wire is broken
	Relay is defective	Replace circuit board with relays (Point 6.3, page 7)
	Limit switch is defective	Replace limit switch (Point 6.0, page 7)
	Indexing wheel does not work properly	Replace indexing wheel and trip cams (Points 4.1.2 and 4.2.3, page 6)

1.5 Ratings and test measurements

1.5.1 Electrical ratings (motor)

	Free run	Friction run
Operating voltage (in volts)	12	12
Current input (amps)	approx. 2.0	max. 5.0

1.5.2 H.F. measuring values

Capacity (aerial with lead), depending on length of telescope and cable
Insulation resistance (measuring frequency 1 MHz)

approx. 70 pF
approx. 250 MΩ

1.5.3 Thrust

Telescopic section

6.5–8.0 kg

2.0 Replacing the telescopic section (52) (53) (54) *

The aerial is installed in the vehicle. The drive works, runs to the limit position in each case and switches off, i.e. the telescope still extends and retracts.

2.1 To dismantle telescopic section

- 2.1.1 Extend telescopic section by switching-on radio.
- 2.1.2 Loosen screw socket on telescope and unscrew from aerial socket (Fig. 2, page 12).
- 2.1.3 Remove telescopic section with plastic wire (Fig. 3, page 12). If the plastic wire is still caught between the drive plate and the pressure bearing (Fig. 6 B, page 13), then retract the telescopic section a little (approx. 15 cm) by switching off the radio.
Switch-on radio again. The telescopic section together with the plastic wire can now be extracted easily.

2.2 Inserting telescopic section

- 2.2.1 First make sure that the aerial drive is „extended“; switch-on the radio.
- 2.2.2 Straighten the end of the plastic wire, approx. 10 cm, by hand.
Note: The end of the wire must be sharpened (Fig. 4, page 12).
- 2.2.3 Insert the end of the plastic wire in the aerial socket (Fig. 5, page 12).
Pass the plastic wire through the stopper (31) in the casing, so that the end of the wire is caught between the drive wheel and the pressure bearing (Fig. 6, 6 A and 6 B, pages 12 and 13).
- 2.2.4 Retract telescopic section and at the same time push the plastic wire and the telescope into the protective sleeve.
- 2.2.5 Screw the screw-socket tightly into the aerial socket (Fig. 2, page 12).
- 2.2.6 Test telescopic section by extending and retracting it several times.

2.3 Replacing telescopic section

The telescopic section is fully or partially extended or bent and cannot be operated.

- 2.3.1 Loosen screw-socket on telescopic section and screw out of aerial socket (Fig. 2, page 12).
- 2.3.2 Pull the telescopic section and plastic wire out of the protective sleeve until the plastic wire can be wound around the hand (Fig. 7, page 13).
Then pull it out of the protective sleeve so hard that the force of the slipping clutch is exceeded.
Now pull out the complete telescopic section (Fig. 3, page 12).
- 2.3.3 Insert new telescopic section (Point 2.2) after having first checked that motor and drive are working properly (Point 2.2.6).

2.4 Replacing telescopic section

The telescopic section is fully retracted and cannot be extended.

- 2.4.1 Dismantle aerial and clean.
- 2.4.2 Remove cover (3) (Point 3.1.2, page 5).
- 2.4.3 Remove retaining ring (23) from the bearing pins of the slip spring (8). Disconnect slip spring and remove (Fig. 8, page 13).
- 2.4.4 Loosen screw-socket on telescope and screw out of aerial socket (Fig. 2, page 12).
- 2.4.5 The telescopic section and plastic wire can now be drawn up and out (Fig. 3 and 7, pages 12 and 13).
- 2.4.6 Replace slip spring (8) and retaining ring (23) (Fig. 8, page 13).
Insert new telescopic section (Point 2.2), but first check that motor and drive are working. Test telescopic section by extending and retracting (Point 3.1.4, page 5).
- 2.4.7 Replace cover (3) and screw tight (Points 3.2.7 and 3.2.8, page 5).

* The number in brackets refers to the corresponding part in fig. 1, pages 8 und 9

3.0 Replacing operational drive (59)

Operational drive does not work properly; can only be replaced after dismantling aerial.

The complete operational drive is the full operational drive for all models of the Auta 6000 H. The drive consists of the motor with motor flange (1), limit switch with printed circuit board and limit switch (complete) (58), as well as the mechanical drive.

3.1 To dismantle operational drive (complete)

(Fig. 10, page 14)

3.1.1 Clean aerial.

3.1.2 Remove cover (3) from the aerial (Fig. 1, pages 8/9); first remove lead seals (45) (46) and screws (25) (28) with sealing rings (26).

Note: The sealing ring (50) is inside the cover.

3.1.3 Dismantle telescopic section (51) (52) (53) according to point 2.1 or point 2.3 or point 2.4.

3.1.4 Extend or retract telescopic section.

To do this, connect outside end of motor cable (42) to a 12 Volt source of current.

To extend: RED and WHITE lead to POSITIVE battery terminal.

BLACK or BROWN lead to NEGATIVE battery terminal (or to chassis where vehicle is negatively earthed).

To retract: RED lead to POSITIVE battery terminal.

BLACK or BROWN lead to NEGATIVE battery terminal (or to chassis where vehicle is negatively earthed).

WHITE lead UNCONNECTED.

3.1.5 Dismantle operation drive (59) (Fig. 10, page 13). Loosen three screws (25) with retaining rings (24) and remove. Remove the three flat plug connections of the cable (43) from the flat tongue sockets on the printed circuit board (5) (Fig. 9, page 13).

3.1.6 Remove operational drive (59) from casing (2) (Fig. 10, page 13) and either replace or repair.

3.2 Installing operational drive (complete)

(Fig. 10, page 14)

3.2.1 Insert operational drive (59) in casing (2). Insert flat plug connections of cable (42) (Fig. 9, page 13).

3.2.2 Grease operational drive (59) and the three screws (25) first lightly with RETINAX C and screw retaining rings (24) tight.

3.2.3 Insert telescopic section (51) (52) (53) according to point 2.2. Connect motor cable to source of current according to point 3.1.4.

3.2.4 **Note:** Place the ratched (21) with the trip cams (22) so that the limit contact at the bottom is open (Fig. 13, page 14) and the ratched engages in the stop spring (27) below it. If the length of the telescope is 1050 mm adjust index 110 (Fig. 12, page 14). Extend and retract aerial several times. Do **not** touch the drive while the aerial is working! There is a danger of being injured by the indexing ring (14) with shift finger.

3.2.5 Check thrust or set according to points 4.2.8 and 4.2.9 (page 6).

3.2.6 After setting the thrust and tightening the hexagonal nuts (17), check whether the shift finger of the indexing ring (14) shows a short overrun at the ratched according to fig. 17 and 18 (page 15). This overrun guarantees that the aerial switches off perfectly in the limit positions (extended or retracted).

3.2.7 Before mounting the cover (3) renew or clean the pipe (20) with inserted stopper (4). For some special models the pipe (20) is cut and without inserted stopper (4). For model Auta 6000 H B52 two stoppers have to be inserted. In any case the upper stopper has to be inserted at least 5 mm from the top rim of the pipe (20).

3.2.8 Assemble cover (3) with enclosed sealing ring (50) on the casing, fasten with screws (25) (28) (grease lightly with RETINAX C before fastening) and the sealing rings (26). Make sure that the individual cable leads are passed into the inside of the casing, so that no wire is clamped between the cover and the casing. After testing, reseal with lead (45) and lead wire (46).

4.0 Mechanical drive (9)—(18)

Dismantling and assembling the drive if prevented from working properly by dirt or if parts of the drive are to be replaced (Fig. 1, pages 8/9).

4.1 Dismantling the mechanical drive

- 4.1.1 Dismantle full operational drive (59) according to point 3.1 (Fig. 10, page 14).
- 4.1.2 Remove ratched (21) and trip cams (22). To do this, remove retaining ring (23).
- 4.1.3 Remove retaining ring (18) from the axle centre, remove the whole drive with the components
worm gear (9),
friction disc (10),
shim (11),
drive wheel (12),
bearing (13),
shim (11),
indexing ring (14),
plate springs (15),
locking plate (16),
hexagonal nut (17).
- 4.1.4 Bend back locking plate (16) (Fig. 16, page 15) with special tool.
- 4.1.5 Screw off nut (17).
- 4.1.6 Take all other components apart and clean them; if necessary, renew them.

4.2 Assembling the mechanical drive

- 4.2.1 Assemble the cleaned or new parts in the sequence according to point 4.1.3, page 6, and fig. 1, pages 8/9.
Note:
 1. The bands of the friction disc (10) must fit into the recesses of the worm gear (9).
 2. Insert the bearing (13) into the drive wheel (12) up to the stop.
 3. Place the two shims (11) on the drive wheel (12). The projections in the drive wheel must jut into the slots in the shims.
 4. Place the components (11) (12) (13) together on the worm gear shaft.
 5. Put on indexing ring (14).
 6. Insert plate springs (15) according to fig. 11, page 14.
 7. Insert locking plate (16).
 8. Screw on hexagonal nut (17) and tighten at approx. 25 cm/kg force.
- 4.2.2 Place drive on motor flange axle centre; but first grease axle and worm gear with Calypsol H 429 F. Insert retaining ring (18).
- 4.2.3 Set ratched and trip cams at Index 110 before placing them on the axle (Fig. 12, page 14).
- 4.2.4 Place ratched (21) on and trip cams (22); mount retaining ring (23) (Point 3.2.4, page 5).
- 4.2.5 Work the ratched with cams in both directions, checking the opening (≥ 0.6 mm) of the contacts of the limit switch (6). If necessary, adjust (Fig. 13 and 14, page 14).
- 4.2.6 Install operational drive (complete) according to point 3.2, page 5. Insert telescope as in point 2.2, page 4.
- 4.2.7 Put aerial into operation (Point 3.1.4, page 5), extend and retract a few times.
- 4.2.8 The aerial telescope must have a thrust of 6,5 to 8,0 kp. If necessary, adjust friction. To to this, tighten hexagonal nut (17) (Fig. 15, page 15).
- 4.2.9 Fix nut (17) with locking plate (16) (Fig. 16, page 15).

5.0 Changing pressure bearing (7)

The ball bearing is soiled or does not operate properly.

5.1 To dismantle pressure bearing

- 5.1.1 Remove slip spring (8) (Point 2.4.3, page 4, fig. 8, page 13, and fig. 19, page 15).
- 5.1.2 Remove retaining ring (23) from bearing pin of pressure bearing (7). Remove complete bearing.
- 5.1.3 Clean or — if necessary (if slackness of bearing is too great) — renew bearing (7).

5.2 To assemble pressure bearing

- 5.2.1 Insert pressure bearing (7). First grease with Calypsol H 429 F.
- 5.2.2 Fix pressure bearing with retaining ring (23).
- 5.2.3 Insert slip spring (8) as in point 2.4.6, page 4, and figures 8 and 19, pages 13 and 15.
- 5.2.4 Test aerial by extending and retracting (Point 3.1.4, page 5).

6.0 To replace or repair complete limit switch (58)

The limit switch compl. (58) consists of the limit switch (6) and printed circuit board with relays (5) (Point 6.3).

6.1 To dismantle complete limit switch

- 6.1.1 Unscrew complete limit switch (58) from operational drive resp. motor flange. Remove nuts (30), toothed discs (29) and washer (57) or cable shoe.
- 6.1.2 If the operational drive (59) is still installed in the casing, then remove the three flat plug connections (on the front side, fig. 9, page 13) and the two flat plug connections (on the back side from the motor, fig. 20, page 16).
- 6.1.3 Remove complete limit switch (58) and if necessary replace or repair.

6.2 To install complete limit switch

- 6.2.1 Insert two flat plug connections (from the motor) at the rear of the printed circuit board (Fig. 20, page 16). Pass the black earth connection forward from the printed circuit board. When fastening the limit switch, the cable spade is placed beneath the upper fixing screw (30) (Fig. 9 and 10, pages 13/14).
- 6.2.2 Screw tight limit switch (58) with screws (30), toothed discs (29) and washer (57) or cable spade from earth connection.
- 6.2.3 Insert the three flat plug connections of the motor cable (42) (Fig. 9, page 13).
- 6.2.4 If the limit switch is to be replaced when the operational drive (compl.) is built into the casing, then extend or retract the telescopic section and check the contact distance in each limit position as in point 4.2.5, page 6, and figs. 13 and 14, page 14.
- 6.2.5 If the limit switch is replaced while the operational drive (compl.) is out, then set the indexing ring (14) or shift finger so that the ratched (21) and the trip cams (22) can be turned. Check contact distance as in point 4.2.5, page 6, and fig. 13 and 14, page 14.

6.3 To assemble limit switch (6) with relay and printed circuit board (5)

These two components – limit switch (6) with two wires and relay with printed circuit board (5) – are supplied as spare parts. The interference suppressors are on the printed circuit board.

- 6.3.1 Insert printed circuit board with relay (5) in the limit switch (6) and engage (Fig. 21, page 16).
- 6.3.2 Solder the two wires of the limit switch at the front to the printed circuit board "C" (Fig. 9, page 13).
- 6.3.3 The complete limit switch (58) is thus installed.

Fully Automatic Car Aerial Auto 6000 H

Spare Parts List

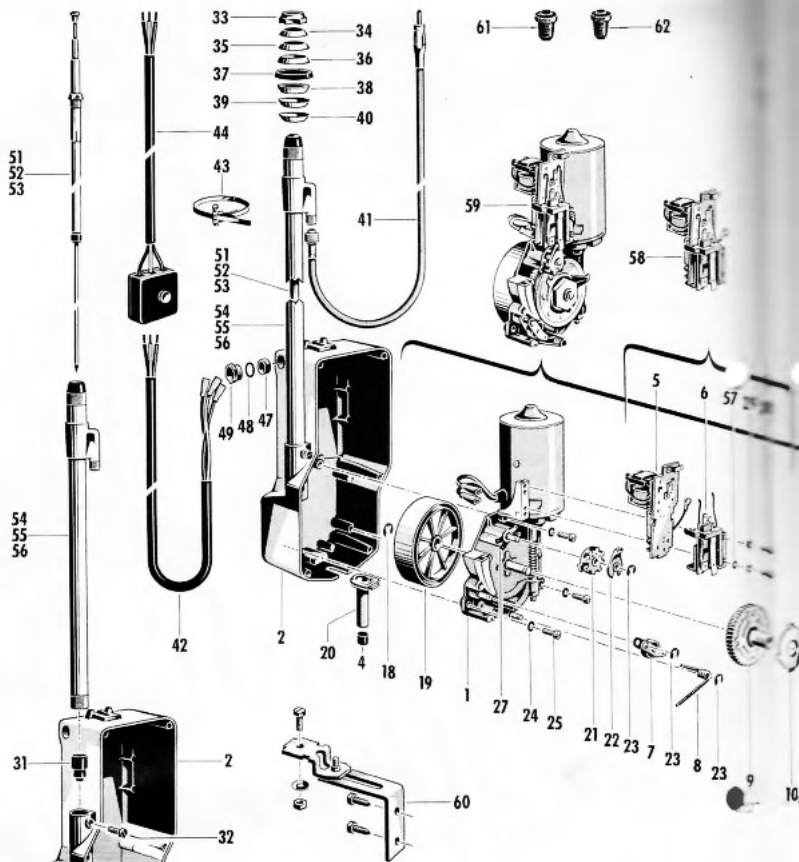

Pos. No.	Item	Auto	Ordering code	Pos. No.	Item	Auto	Ordering code
1	Motor flange, complete	6905	824 212	34	Dished ring 1	4312	722 897
2	Casing	6917	724 266	35	Dished ring 2	4313	722 898
3	Cover	6916	724 263	36	Upper-ring	4314	722 899
4	Stopper	8114	725 037	37	Sealing washer	4315	722 919
5	Circuit board, complete	6950	824 289	38	Under-ring	4316	722 930
6	Limit switch	8377	825 137	39	Dished ring	4317	722 913
7	Pressure bearing, complete	6940	824 211	40	Dished ring	4318	722 914
8	Worm gear	6931	724 207	41	Aerial lead	Aukab	
9	Friction disc	6935	824 209			150/130	825 943-005
10	Shim	6912	724 202	42	Motor cable	6965	824 397
11	Drive wheel	8272	724 914	43	Hose clip	1064	822 661
12	Bearing	6925	824 226	44	Lead with fuse carrier	6460	822 218
13	Indexing ring	6928	724 264	45	Lead seal	6536	722 254
14	Plate spring	6927	724 208	46	Seal wire	6537/720	722 255-002
15	Locking plate	6956	724 312	47	Sealing ring	6592	724 494
16	Nut	6929	724 265	48	Thrust ring	Stas 3-7	730 140
17	Retaining ring 6 DIN 6799	6922	724 205	49	Press ring	6891	724 493
18	Drum	6911	258 854	50	Gasket	6924	724 392
19	Pipe	6961	724 201	51	Telescope, brass, 3-section, 1050 mm long	6960	824 295-002
20	Ratched	6937	724 282	52	Telescope, brass, 3-section, 1050 mm long, for Auto 8000 H 88 only	6960	824 295-004
21	Trip cams	6936	724 279	53	Telescope, stainless steel, 4-section, 1050 mm long	6966	824 454-001
22	Retaining ring 4 DIN 6799		258 853	54	Protective sleeve, complete, for brass telescope, 1050 mm long	6954	824 290-002
23	Spring washer B 4 DIN 127		250 851	55	Protective sleeve, complete, for stainless steel telescope, 1050 mm long	6954	824 290-004
24	Cheese head screw AM 4 x 12 DIN 84		250 085	56	Protective sleeve, complete, for Auto 5000 H 88 only	6954	824 290-005
25	Sealing ring	6194	727 247	57	Washer 3.2 DIN 433		254 204
26	Stop ring	6932	724 269	58	Limit switch, complete	6945	824 409
27	Phillips screw AM 4 x 12 DIN 404		259 701	59	Operational drive, complete	6916	824 274
28	Toothed disc A 3.2 DIN 6797		257 307	60	Bracket complete	6968	824 412
29	Cheese head screw AM 3 x 8 DIN 84		250 018	61	Rubber socket for motor cable	6812	723 964-009
30	Stopper	8116	725 042	62	Rubber socket for telescope cable	4281	722 429-009
31	Screw	6538	720 357				
32	Nut	4311	722 912				

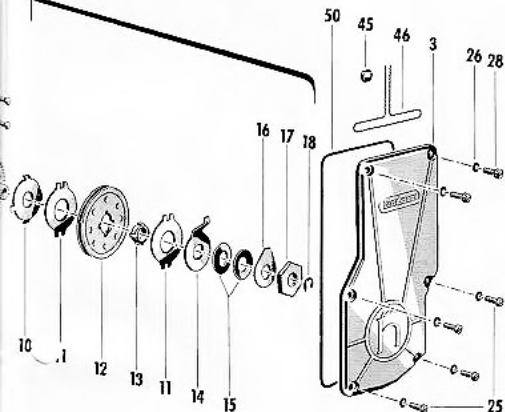

7.0 To replace aerial drum (19)

Note: When dismantling or repairing the operational drive, complete (59) (Points 3.1–4.2, page 5/6), it is advisable to clean or repair the aerial drum for the plastic wire in every case.

7.1 To dismantle drum

The drum cannot be replaced unless the operational drive (compl.) has been removed from the casing.

7.1.1 Remove retaining ring (18) and then drum (19) from the axle of the motor flange (1).

7.1.2 Clean drum – especially the winding space – or renew drum if necessary.

7.2 To install drum

7.2.1 Grease the winding space of the drum and hole of 8 mm dia. with Calypsol H 429 F.

7.2.2 Place drum (19) on axle and secure with retaining ring (18).

Make sure that the drum can be turned **easily**, if necessary work the running surface (Fig. 22 at "D", page 16). Also make sure that the play of 0,8 mm between the drum and the flange (Fig. 22 at "E", page 16) **does not exceed** this amount, as otherwise the plastic wire may get caught between the drum and flange when being wound up.

8.0 To replace protective sleeve completely (54) (55) (56)

This can only be done when the aerial has been removed from the vehicle.

8.1 To dismantle protective sleeve

(Fig. 23, page 16)

- 8.1.1** Unbolt aerial cable (41).
- 8.1.2** Remove telescopic section (51) (52) (53) (Points 2.0 to 2.4, page 4).
- 8.1.3** Remove motor cable (42) from protective sleeve. To do this, remove metal hose band – with lock (43).
- 8.1.4** Unscrew locking screw (32).
- 8.1.5** Screw protective sleeve (54) (55) (56) out of casing (2), clean or replace if necessary.
- 8.1.6** Remove plastic stopper (31) and clean or replace if necessary.

8.2 To install protective sleeve

- 8.2.1** Insert plastic stopper (31). Make sure that the lower end (6,3 mm diameter) juts through the hole "F" in the casing (Fig. 23, page 16).
- 8.2.2** Grease thread on protective sleeve slightly with RETINAX C. Screw in protective sleeve until it touches the stopper (31) slightly (Fig. 23, page 16).
Note, that the cable at the sleeve joint must have the same position then before the removing of the conduit.
- 8.2.3** Tighten locking screw (32).
- 8.2.4** Fix motor cable (42) with hose band on the conduit. Screw aerial cable (41) to aerial socket.
- 8.2.5** Install telescopic section (Points 2.0 to 2.4, page 4).
- 8.2.6** Test aerial by extending and retracting several times (Point 3.1.4, page 5).

51
52
53

ZU

AUF

2

51
52
53

3

51
52
53

10 cm

4

31

A

B

Hirschmann

12

5

6

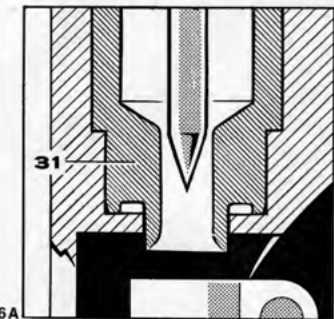

6A

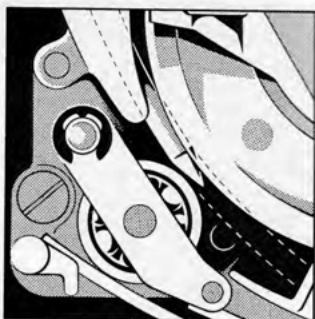

6B

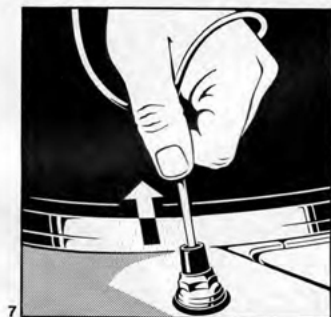

7

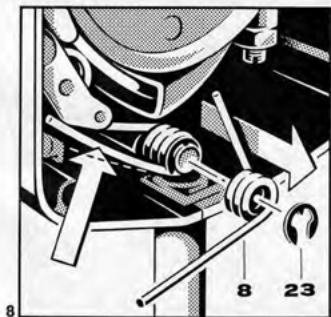

8

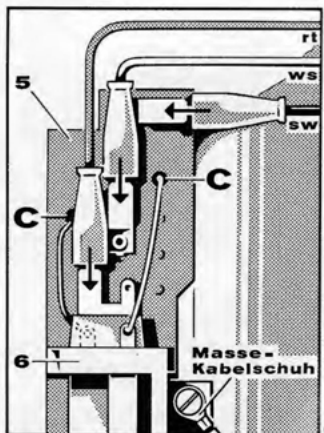

9

